

LEISTER

PROCESS HEAT



Air heaters LHS 15 and LHS 21



Powerful with full
integration option.

Air heaters LHS 15 and LHS 21: Reliable technological leaders

These advanced air heaters are distinguished by their extremely small dimensions – especially the lean design with only 67 mm width – as well as their long service life. Designed for professional integration in machine systems, the new LHS series enables any specific application. Sterilisation, drying, welding, cleaning, shrinking, shaping, deburring and activation are now more efficient and reliable thanks to Leister's proven hot air technology!

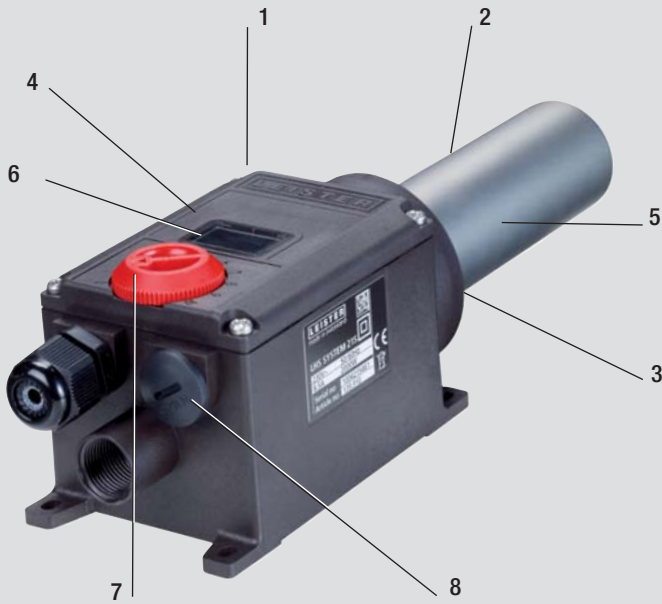

1		Compact: Small dimensions for installation in tight spaces in mechanical engineering
2		Reliable: Very durable heating elements thanks to innovative, patented heating element protection
3		Service friendly: Faster and easier heating element change
4		Power electronics: On-tool power electronics do away with the need for external SSR (e.g. semiconductor relay)
5		Thermocouple: The integral thermocouple in SYSTEM devices improves precision and simplifies reproducibility
6		User friendly: The display of the SYSTEM devices gives users precise local information

7 Different designs for diverse requirements

LHS CLASSIC for permanent full heat capacity or for installation of an individual, external power control. Passive overheat protection.
LHS PREMIUM for manual adjustment of the air outlet temperature. Active overheat protection.
LHS SYSTEM for integration in a closed temperature control loop. Active overheat protection. Various operating modes possible.

8 Professional integration or controlled stand-alone operation

Operation modes LHS SYSTEM	Control mode	Adjustment mode
Internal (potentiometer) set point	Temperature set point by potentiometer Display shows temperature set point & actual temperature	Capacity set point by potentiometer Display shows capacity set point in % and actual temperature
External (Interface) set point	Temperature set point by external controller Display shows temperature set point & actual temperature	Capacity set point by external controller Display shows capacity set point in % and actual temperature





LHS 21 S

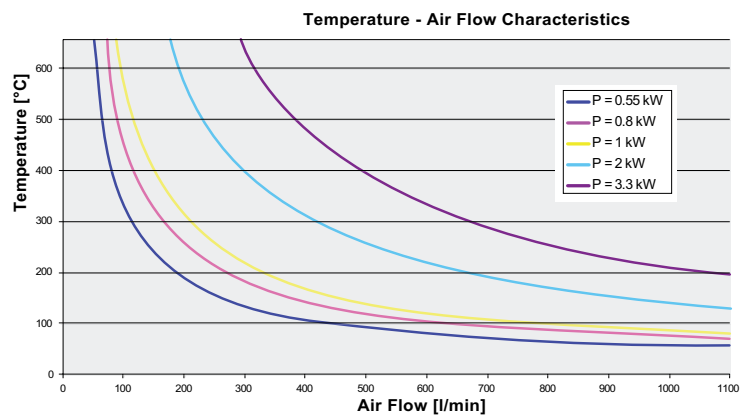

Features

- Compact for installation in tight spaces in mechanical engineering
- Reliable thanks to PATENTED heating element protection
- Low maintenance costs and high availability through durable heating elements
- Cost saving thanks to fully integrated open and closed loop control
- Standard control interface for easy integration in existing controls
- Temperature up to 650 °C

Dimensions in mm

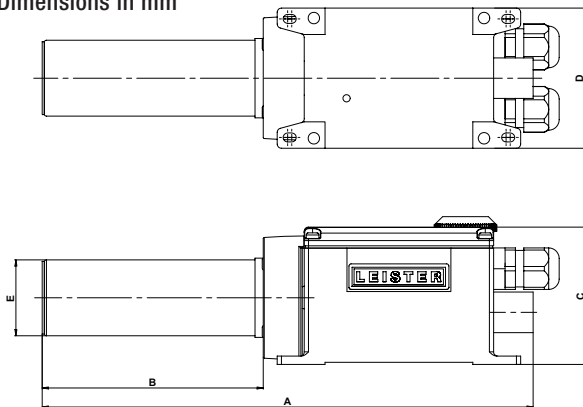

Type	A	B	C	D	E
LHS 15	201	77	51	67	∅ 21,3
LHS 21S	236	106	66	67	∅ 36,5
LHS 21L	266	136	66	67	∅ 36,5

Technical data

Max. air outlet temperature	°C	650
Max. air inlet temperature	°C	65
Max. ambient temperature	°C	80
Min. airflow	As per above diagram	
Relative humidity	%	5 – 95 non condensing
Max. inlet pressure	bar	2
Weight 15/21S/21L	kg	0.48 / 0.58 / 0.68
Conformity mark		CE
Type of certification		CCA
Protection class II		□

Accessories LHS 15 and LHS 21

106.956		Thermocouple with plug, 1 m cable	> All Air Heaters
107.310 107.311		Sieve reflector, push-fit (a x b) 20 x 35 mm 50 x 35 mm	> LHS 15
105.549 105.559 105.548 105.547		Wide slot nozzle, push-fit (a x b) 10 x 2 mm, angled 20 x 2 mm, length 55 mm 40 x 5 mm 50 x 8 mm	> LHS 15
107.261 108.078 105.982		Wide slot nozzle, push-fit (a x b) 70 x 4 mm 100 x 4 mm 150 x 4 mm	> LHS 21
107.308 107.309		Sieve reflector, push-fit (a x b) 35 x 50 mm 20 x 35 mm	> LHS 21
107.134		Spoon reflector, push-fit (a x b) 25 x 30 mm	> LHS 21
107.319		Sieve reflector, push-fit ∅ 65 mm	> LHS 21
106.132		Shell reflector, push-fit (a x b) (a x b) 150 x 25 mm	> LHS 21

Order no.:

		CLASSIC	PREMIUM	SYSTEM
LHS 15	0.55 kW / 120V	139.873	139.908	139.894
LHS 15	0.8 kW / 230V	139.874	139.893	139.895
LHS 21S	1.0 kW / 120V	139.868	140.454	140.458
LHS 21S	1.0 kW / 230V	139.869	140.455	140.459
LHS 21S	2.0 kW / 120V	139.870	140.456	140.460
LHS 21S	2.0 kW / 230V	139.871	139.909	139.910
LHS 21L	3.3 kW / 230V	139.872	140.457	140.461

Contact a Leister sales partner in your region for professional advice and information on our other air heaters and blowers.

Headquarters:

Leister Process Technologies
Galileo-Strasse 10
CH-6056 Kaegiswil/Switzerland
phone: +41 41 662 74 74
fax: +41 41 662 74 16
leister@leister.com
sales@leister.com

Leister Technologies LLC
1253 Hamilton Parkway
Itasca, IL 60143/USA
phone: +1 630 760 1000
fax: +1 630 760 1001
sales@leisterusa.com

Leister Technologies Ltd.
Building A, 1588 Zhuanxing Road
Shanghai 201 108 PRC
phone: +86 21 6442 2398
fax: +86 21 6442 2338
leister@leister.cn

Leister Technologies KK
Shinyokohama Bousei Bldg 1F
3-12-20, Shinyokohama, Kohoku-ku,
Yokohama 222-0033
phone: +81 (45) 477 3637
fax: +81 (45) 477 3638
sales-japan@leister.com

Our close worldwide network of more than 120 Sales and Service Centers in more than 90 countries.

Europe:

Austria
Belgium
Bulgaria
Croatia
Cyprus
Czech Republic

Estonia
Denmark
Finland
France
Germany
Great Britain
Greece

Hungary
Ireland
Iceland
Italy
Latvia
Lithuania
Netherlands

Normay
Poland
Portugal
Romania
Russia
Serbia
Slovakia

Slovenia
Spain
Sweden
Switzerland
Turkey
Ukraine



Leister Technologies LLC
Itasca, IL, USA

America:

Canada
Mexico
USA
Argentina
Brazil
Chile
Peru

Leister Process Technologies
Headquarters and Manufacturing
Kaegiswil, Switzerland

Leister Technologies KK
Yokohama, Japan

Leister Technologies Ltd.
Shanghai, China

Africa:

Egypt
Kenya
Morocco
South Africa

Asia:

P. R. China
Hong Kong
India
Indonesia
Iran

Japan
Korea
Malaysia
Philippines
Saudi Arabia
Singapore

United Arab Emirates
Taiwan
Thailand
Vietnam

Oceania:

Australia
New Zealand

Distributor Address: